

PRODUCT TECHNICAL DATASHEET

BM30/303/HS

Brushless 

Intensive use 

High Speed 

Digital Encoder 

Mechanic limit switch 



CODE	DESCRIPTION	PCS/PALLET
BM30/303/HS	Electromechanical HIGH SPEED BRUSHLESS motor, low voltage, super intensive use, irreversible, ideal for sliding gates up to 400 kg with built-in digital controller B70 series, mechanical limit switch.	44

PRODUCT TECHNICAL SPECIFICATIONS	
Max gate weight	400 kg
Power line supply	230V AC - 50Hz
Motor power supply	24V
Power rating	125W
Frequency of use	Intensive use
Thrust	50 - 350N
Operating temperature	-20+55°C
Protection level	IP43
Reductor Type	Irreversible
Manoeuvre speed	26 m/min (0.44 m/s)
Limit switch	Mechanical
Onboard control unit	B70/1DC
Encoder	Digital native encoder + magnetic digital SENSORED, 4096 PPR
Type exit gear	Z15/mod 4
Operating cycles per day (opening/closing - 24 hours no stop)	500
Maximum dimension product in mm (L x W x H)	250 x 165 x 290

Product weight packed (Kg) 10,4

Number items per pallet 44

PRODUCT DIMENSIONS AND PREPARING FOR INSTALLATION

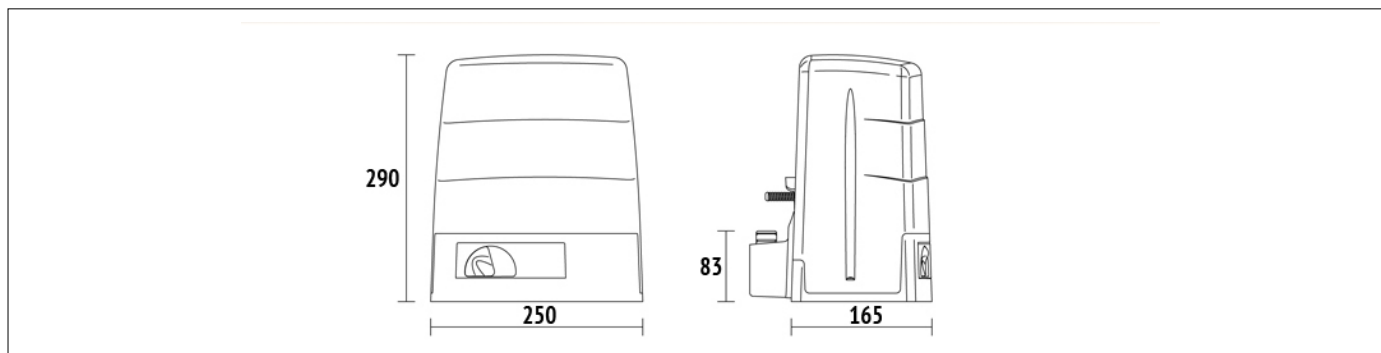

DIMENSIONS

PRODUCT PREPARING FOR INSTALLATION

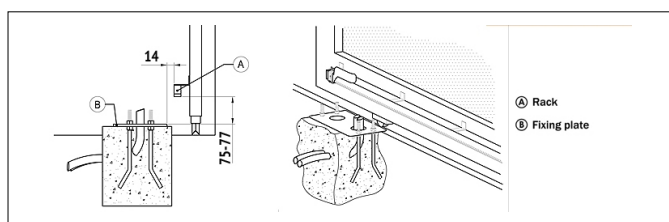

PREDISPOSITION FOR STANDARD INSTALLATION

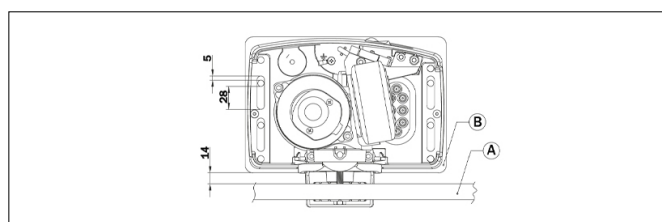

PREDISPOSITION FOR STANDARD INSTALLATION

PRODUCT ACCESSORIES



B71/PBX24/BOX
Battery chargers with solar panels for powering Brushless digital controllers at 24V DC in network mode.



B71/PBX24/BOX/115
Battery chargers with solar panels for powering Brushless digital controllers at 24V DC in network mode.



B71/PBX/BOX
Battery chargers with solar panels for powering Brushless digital controllers in FULL SOLAR mode.



KT220
Raised fixing plate for M30 series (+3 cm).

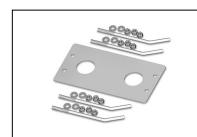

KT223
Fixing plate with stay bolts and screws M30 series.



GA550
Galvanised steel rack 22x22x1000 module 4.



GA551
Galvanised steel rack 30x12x1000 module 4 with spacers and screws.



GA554
Pocket of 6 spacers (2,5 cm) and screws.

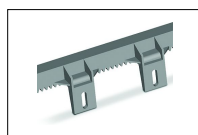

GA553
Nylon rack module 4 with 6 connectors L.1000.



GA557
Roger Technology nylon rack module 4 with 6 connectors L.1000.



MC773
Kit mechanical limit switch for control unit H70/103AC, H70/104AC, B70/1DC, B70/1DCHP.



R99/C/001AL
Signboard "Automatic Opening" Aluminium version



R99/C/001
Signboard "Automatic Opening".