

8

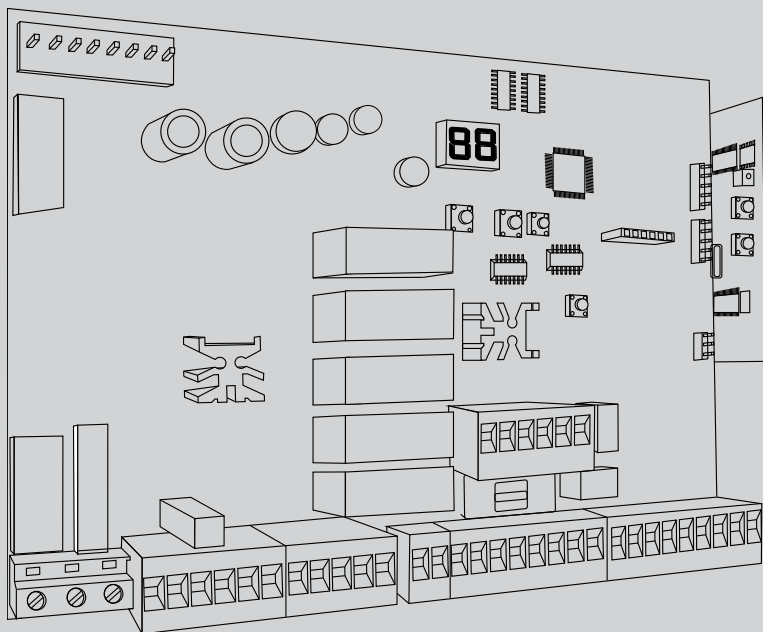

D811944\_03-07-08-12

QUADRO COMANDO  
 CONTROL PANEL  
 CENTRALE DE COMMANDE  
 SELBSTÜBERWACHENDE STEUERUNG  
 CUADRO DE MANDOS  
 QUADRO DE COMANDO



ISTRUZIONI DI INSTALLAZIONE  
 INSTALLATION MANUAL  
 INSTRUCTIONS D'INSTALLATION  
 MONTAGEANLEITUNG  
 INSTRUCCIONES DE INSTALACION  
 INSTRUÇÕES DE USO E DE INSTALAÇÃO

# PERSEO CBD 230.P SD

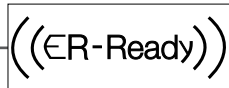

AZIENDA CON SISTEMA DI GESTIONE  
 INTEGRATO CERTIFICATO DA DNV  
 = UNI EN ISO 9001:2008 =  
 UNI EN ISO 14001:2004

# INSTALLAZIONE VELOCE-QUICK INSTALLATION-INSTALLATION RAPIDE SCHNELLINSTALLATION-INSTALACIÓN RÁPIDA - INSTALAÇÃO RÁPIDA

PREDISPOSIZIONE TUBI, TUBE ARRANGEMENT,  
PRÉDISPOSITION DES TUYAUX, VORBEREITUNG DER LEITUNGEN,  
DISPOSICIÓN DE TUBOS, DISPOSIÇÃO DOS TUBOS

**A**

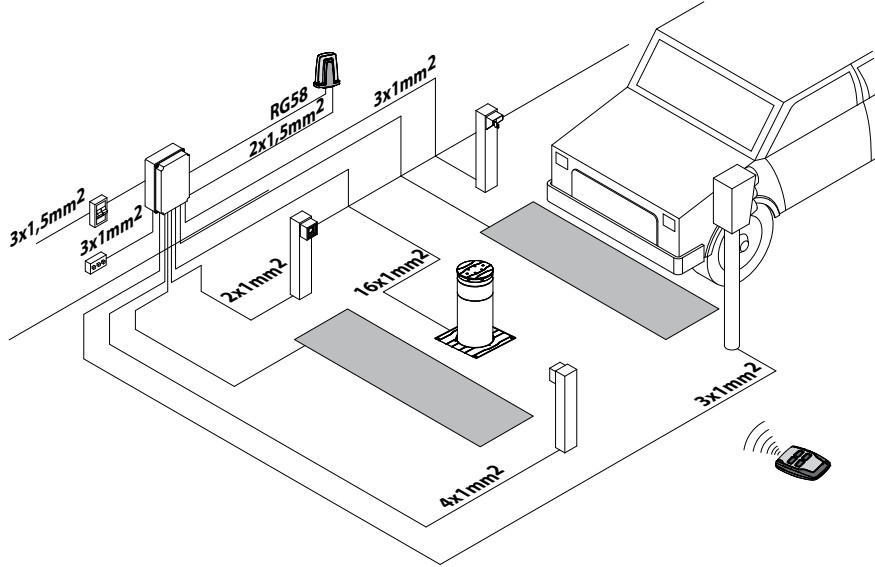

**B**

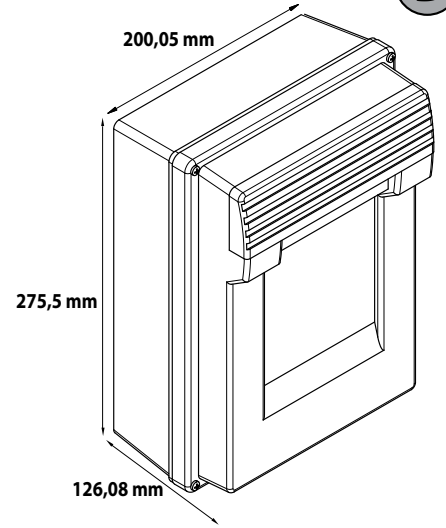

**C**

Connettore Trasformatore/  
Transformer Connector/  
Connecteur Transformateur/  
Steckverbindung Transformator/  
Conector Transformador/  
Conector Transformador

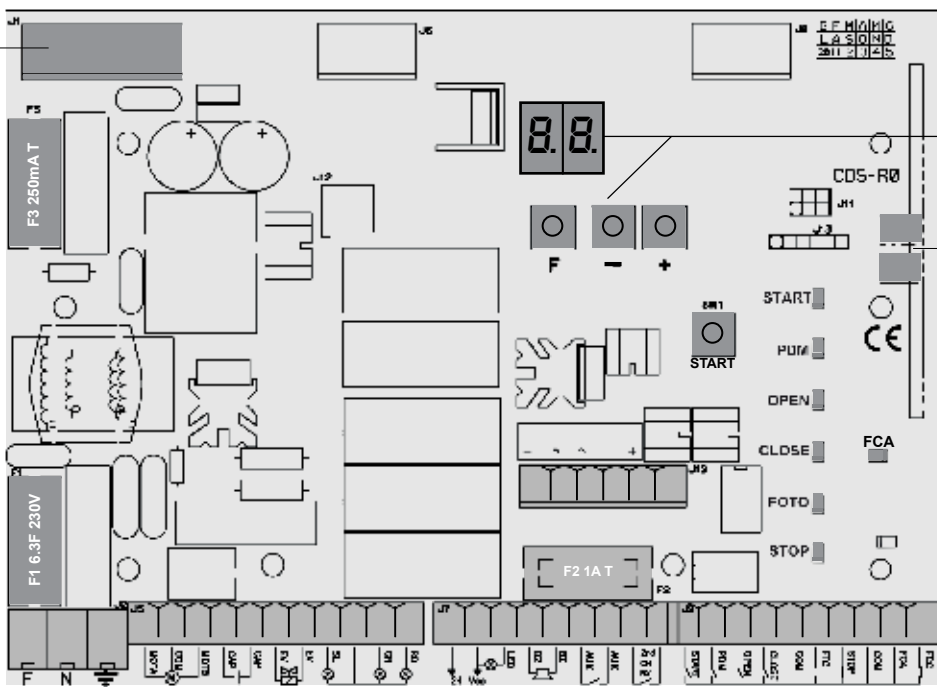

Display + Tasti programmazione/  
Display + programming keys  
Afficheur + touches programmation/  
Display + Programmierungstasten/  
Pantalla + botones programación/  
Display mais teclas de programação

Ricevente radio integrata/  
Built-in radio-receiver/  
Récepteur radio intégré/  
Integrierter Funkempfänger/  
Receptor radio incorporado /  
Receptor rádio integrado

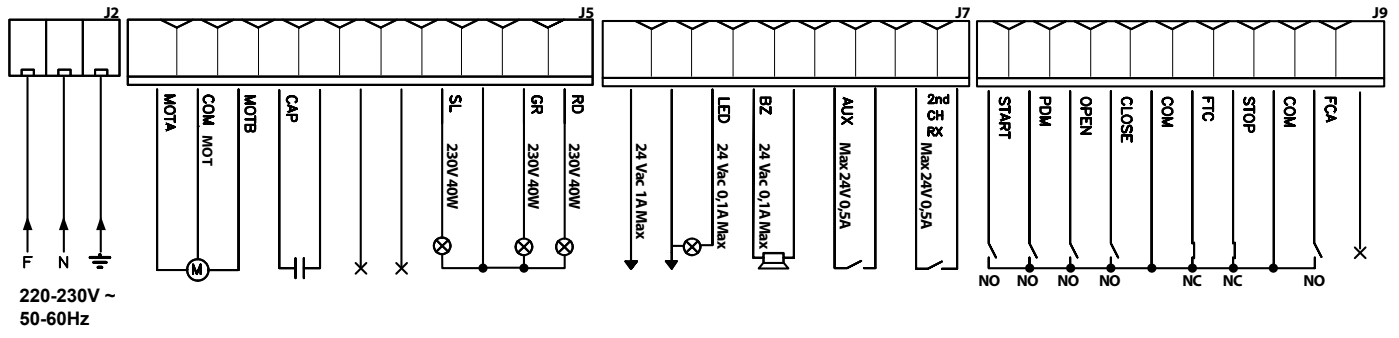
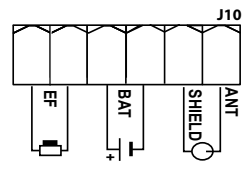

D

**SELEZIONE DISSUASORE - SELECT BOLLARD -  
SÉLECTION BORNE ESCAMOTABLE  
AUSWAHL POLLER - SELECCIÓN DISUASOR - SELEÇÃO DISSUASOR**

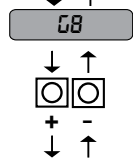
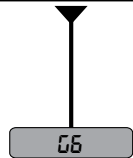
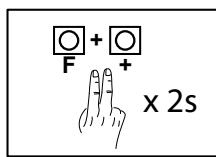

....h5, h8, d5....

Salvataggio e Uscita / Save and Exit / Sauvegarde et Sortie /  
Speichern und Verlassen / Guardado y Salida /  
Guardar e Sair



LEGENDA - KEY - LÉGENDE - LEGENDE - LEYENDA - LEGENDA	
<b>E5</b>	Non disponibile, Not available, Pas disponible, Nicht verfügbar, No disponible, Não disponível
<b>E8</b>	Non disponibile, Not available, Pas disponible, Nicht verfügbar, No disponible, Não disponível
<b>h8</b>	Non disponibile, Not available, Pas disponible, Nicht verfügbar, No disponible, Não disponível
<b>d5</b>	STOPPY MBB 219-500 C.
<b>d7</b>	STOPPY MBB 219-700 C.
<b>E5</b>	Non disponibile, Not available, Pas disponible, Nicht verfügbar, No disponible, Não disponível
<b>E7</b>	Non disponibile, Not available, Pas disponible, Nicht verfügbar, No disponible, Não disponível
<b>F7</b>	Non disponibile, Not available, Pas disponible, Nicht verfügbar, No disponible, Não disponível

**!** Selezionare frequenza di rete tramite parametro **h5**.  
Select mains frequency using **h5** parameter.  
Sélectionner la fréquence du secteur avec le paramètre **h5**.  
Wählen Sie die Netzfrequenz mit dem Parameter **h5**.  
Seleccionar frecuencia de red mediante parámetro **h5**.  
Seleccionar a frequência de rede mediante o parâmetro **h5**.

LEGENDA - KEY - LÉGENDE - LEGENDE - LEYENDA - LEGENDA		
<b>E5</b>	+	Scorri avanti / Scroll forward / Défiler vers l'avant / Bildlauf vor / Desplazar hacia delante / Navegar para frente
<b>E8</b>	-	Scorri indietro / Scroll back / Défiler vers l'arrière / Bildlauf zurück / Desplazar hacia atrás / Navegar para trás
<b>F</b>	<b>F++x2s</b>	Accesso al menu / Call up menu / Accès au menu / Zugang zum Menü / Acceso al menú / Acesso ao menu
<b>F</b>	<b>F++</b>	Salvataggio e uscita / Save and exit / Sauvegarde et sortie / Speichern und Verlassen / Guardado y salida / Guardar e sair

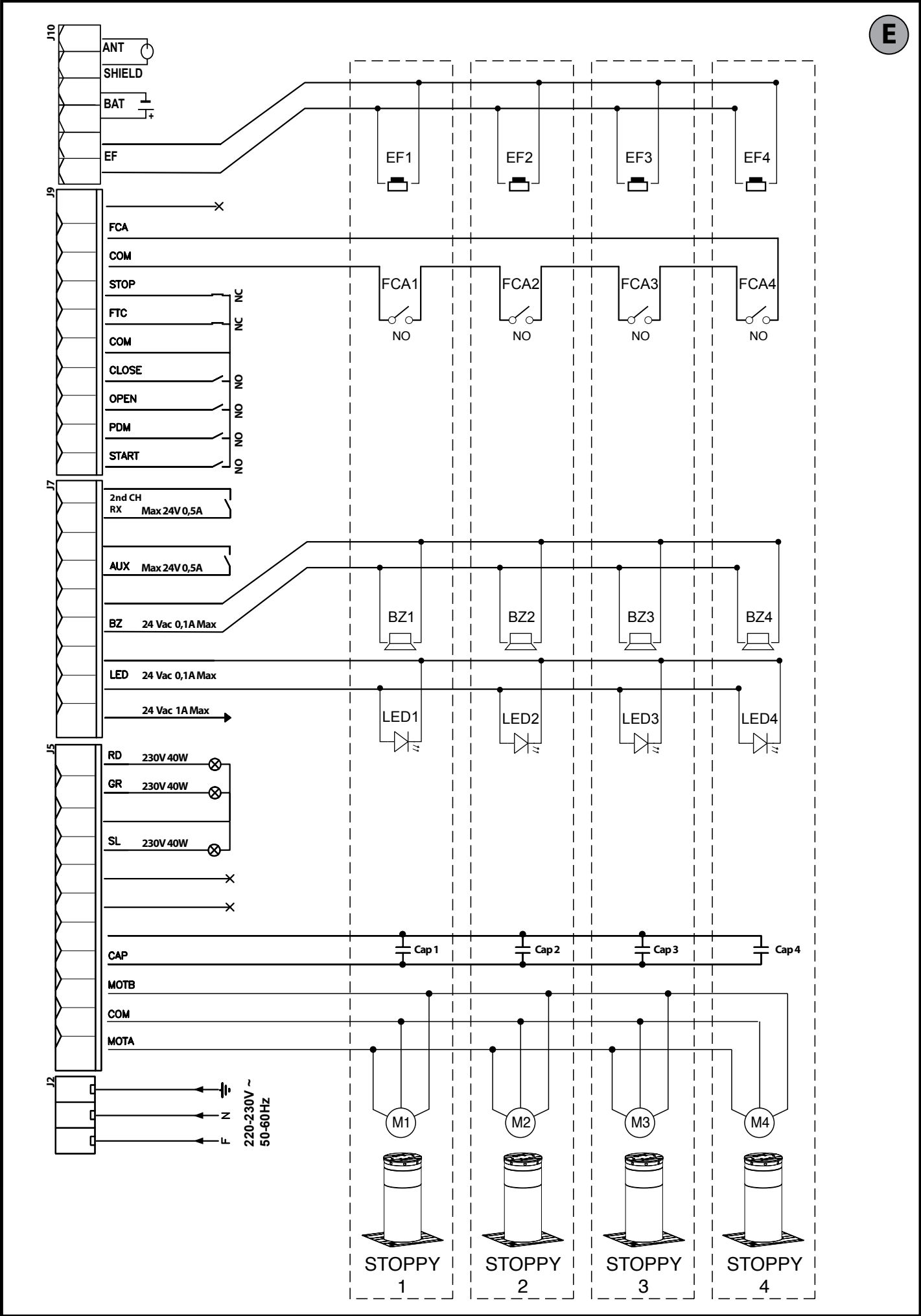

CALLING UP MENUS Fig.1

ENGLISH

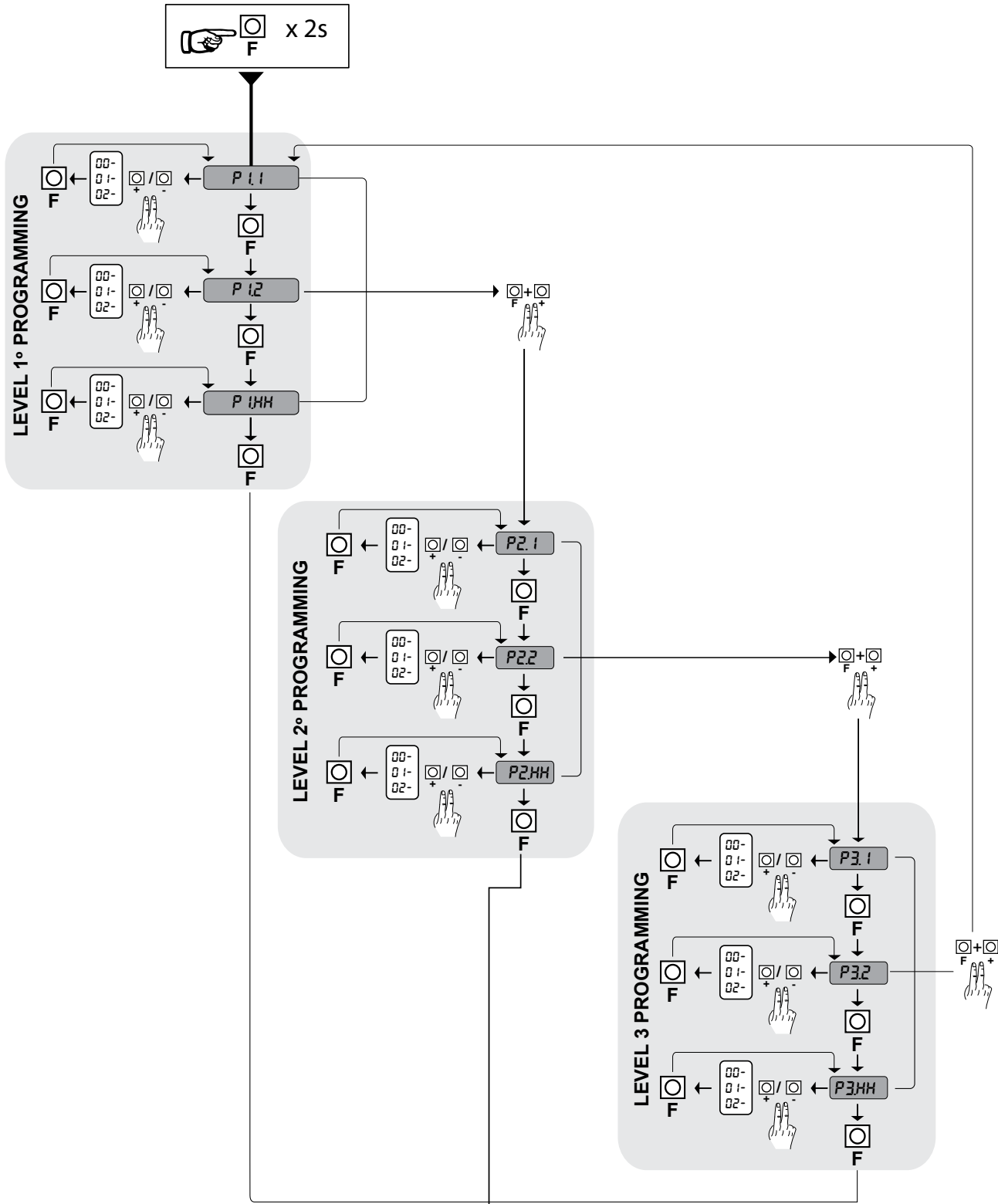

**F**

**-**

**+**

- F** Confirm
- +** Scroll forward
- Scroll back
- F**<sup>x2s</sup> Access to programming
- F++** Next programming level

St  
  
**F**  
 ↓  
 EXIT

Diagnostics code	Description	Notes
01	Idle	
02	Opening	
03	Stop opening limit switch	
04	Stop opening	
05	Closing	
06	Stop closing limit switch	
07	Stop closing	
08	Stop due to photocell triggering	
09	Opening due to photocell triggering	
10	Photocell triggering pause	
14	Maximum working time in opening reached	
15	Maximum working time in closing reached	

## INSTALLER WARNINGS

D811944\_03

**WARNING! Important safety instructions. Carefully read and comply with all the warnings and instructions that come with the product as incorrect installation can cause injury to people and animals and damage to property. The warnings and instructions give important information regarding safety, installation, use and maintenance. Keep hold of instructions so that you can attach them to the technical file and keep them handy for future reference.**

### GENERAL SAFETY

This product has been designed and built solely for the purpose indicated herein. Uses other than those indicated herein might cause damage to the product and create a hazard.

-The units making up the machine and its installation must meet the requirements of the following European Directives, where applicable: 2004/108/EC, 2006/95/EC, 2006/42/EC, 89/106/EC, 99/05/EC and later amendments. For all countries outside the EEC, it is advisable to comply with the standards mentioned, in addition to any national standards in force, to achieve a good level of safety.

-The Manufacturer of this product (hereinafter referred to as the "Firm") disclaims all responsibility resulting from improper use or any use other than that for which the product has been designed, as indicated herein, as well as for failure to apply Good Practice in the construction of entry systems (doors, gates, etc.) and for deformation that could occur during use.

-Before installing the product, make all structural changes required to produce safety gaps and to provide protection from or isolate all crushing, shearing and dragging hazard areas and danger zones in general in accordance with the provisions of standards EN 12604 and 12453 or any local installation standards. Check that the existing structure meets the necessary strength and stability requirements.

-Before commencing installation, check the product for damage.

-The Firm is not responsible for failure to apply Good Practice in the construction and maintenance of the doors, gates, etc. to be motorized, or for deformation that might occur during use.

-Make sure the stated temperature range is compatible with the site in which the automated system is due to be installed.

-Do not install this product in an explosive atmosphere: the presence of flammable fumes or gas constitutes a serious safety hazard.

-Disconnect the electricity supply before performing any work on the system. Also disconnect buffer batteries, if any are connected.

-Before connecting the power supply, make sure the product's ratings match the mains ratings and that a suitable residual current circuit breaker and overcurrent protection device have been installed upline from the electrical system. Have the automated system's mains power supply fitted with a switch or omnipolar thermal-magnetic circuit breaker with a contact separation that meets code requirements.

-Make sure that upline from the mains power supply there is a residual current circuit breaker that trips at no more than 0.03A as well as any other equipment required by code.

-Make sure the earth system has been installed correctly: earth all the metal parts belonging to the entry system (doors, gates, etc.) and all parts of the system featuring an earth terminal.

-Installation must be carried out using safety devices and controls that meet standards EN 12978 and EN 12453.

-Impact forces can be reduced by using deformable edges.

-In the event impact forces exceed the values laid down by the relevant standards, apply electro-sensitive or pressure-sensitive devices.

-Apply all safety devices (photocells, safety edges, etc.) required to keep the area free of impact, crushing, dragging and shearing hazards. Bear in mind the standards and directives in force, Good Practice criteria, intended use, the installation environment, the operating logic of the system and forces generated by the automated system.

-Apply all signs required by current code to identify hazardous areas (residual risks). All installations must be visibly identified in compliance with the provisions of standard EN 13241-1.

-Once installation is complete, apply a nameplate featuring the door/gate's data. This product cannot be installed on leaves incorporating doors (unless the motor can be activated only when the door is closed).

-If the automated system is installed at a height of less than 2.5 m or is accessible, the electrical and mechanical parts must be suitably protected.

-Install any fixed controls in a position where they will not cause a hazard, away from moving parts. More specifically, hold-to-run controls must be positioned within direct sight of the part being controlled and, unless they are key operated, must be installed at a height of at least 1.5 m and in a place where they cannot be reached by the public.

-Apply at least one warning light (flashing light) in a visible position, and also attach a Warning sign to the structure.

-Attach a label near the operating device, in a permanent fashion, with information on how to operate the automated system's manual release.

-Make sure that, during operation, mechanical risks are avoided or relevant protective measures taken and, more specifically, that nothing can be banged, crushed, caught or cut between the part being operated and surrounding parts.

-Once installation is complete, make sure the motor automation settings are correct and that the safety and release systems are working properly.

-Only use original spare parts for any maintenance or repair work. The Firm disclaims all responsibility for the correct operation and safety of the automated system if parts from other manufacturers are used.

-Do not make any modifications to the automated system's components unless explicitly authorized by the Firm.

-Instruct the system's user on what residual risks may be encountered, on the control systems that have been applied and on how to open the system manually in an emergency, give the user guide to the end user.

-Dispose of packaging materials (plastic, cardboard, polystyrene, etc.) in accordance with the provisions of the laws in force. Keep nylon bags and polystyrene out of reach of children.

### WIRING

**WARNING!** For connection to the mains power supply, use: a multicore cable with a cross-sectional area of at least 5x1.5mm<sup>2</sup> or 4x1.5mm<sup>2</sup> when dealing with three-phase power supplies or 3x1.5mm<sup>2</sup> for single-phase supplies (by way of example, type H05 VV-F cable can be used with a cross-sectional area of 4x1.5mm<sup>2</sup>). To connect auxiliary equipment, use wires with a cross-sectional area of at least 0.5 mm<sup>2</sup>.

- Only use pushbuttons with a capacity of 10A-250V or more.

- Wires must be secured with additional fastening near the terminals (for example, using cable clamps) in order to keep live parts well separated from safety extra low voltage parts.

- During installation, the power cable must be stripped to allow the earth wire to be connected to the relevant terminal, while leaving the live wires as short as possible. The earth wire must be the last to be pulled taut in the event the cable's fastening device comes loose.

**WARNING!** safety extra low voltage wires must be kept physically separate from low voltage wires.

Only qualified personnel (professional installer) should be allowed to access live parts.

### CHECKING THE AUTOMATED SYSTEM AND MAINTENANCE

Before the automated system is finally put into operation, and during maintenance work, perform the following checks meticulously:

-Make sure all components are fastened securely.

-Check starting and stopping operations in the case of manual control.

-Check the logic for normal or personalized operation.

-For sliding gates only: check that the rack and pinion mesh correctly with 2 mm of play along the full length of the rack; keep the track the gate slides on clean and free of debris at all times.

-For sliding gates and doors only: make sure the gate's running track is straight and horizontal and that the wheels are strong enough to take the weight of the gate.

-For cantilever sliding gates only: make sure there is no dipping or swinging during operation.

-For swing gates only: make sure the leaves' axis of rotation is perfectly vertical.

-Check that all safety devices (photocells, safety edges, etc.) are working properly and that the anti-crush safety device is set correctly, making sure that the force of impact measured at the points provided for by standard EN 12445 is lower than the value laid down by standard EN 12453.

-Impact forces can be reduced by using deformable edges.

-Make sure that the emergency operation works, where this feature is provided.

-Check opening and closing operations with the control devices applied.

-Check that electrical connections and cabling are intact, making extra sure that insulating sheaths and cable glands are undamaged.

-While performing maintenance, clean the photocells' optics.

-When the automated system is out of service for any length of time, activate the emergency release (see "EMERGENCY OPERATION" section) so that the operated part is made idle, thus allowing the gate to be opened and closed manually.

-If the power cord is damaged, it must be replaced by the manufacturer or their technical assistance department or other such qualified person to avoid any risk.

-If "D" type devices are installed (as defined by EN12453), connect in unverified mode, foresee mandatory maintenance at least every six months

### WARNING!

Remember that the drive is designed to make the gate/door easier to use and will not solve problems as a result of defective or poorly performed installation or lack of maintenance

### SCRAPPING

Materials must be disposed of in accordance with the regulations in force. There are no particular hazards or risks involved in scrapping the automated system. For the purpose of recycling, it is best to separate dismantled parts into like materials (electrical parts - copper - aluminium - plastic - etc.).

### DISMANTLING

If the automated system is being dismantled in order to be reassembled at another site, you are required to:

-Cut off the power and disconnect the whole electrical system.

-Remove the actuator from the base it is mounted on.

-Remove all the installation's components.

-See to the replacement of any components that cannot be removed or happen to be damaged.

**Anything that is not explicitly provided for in the installation manual is not allowed. The operator's proper operation can only be guaranteed if the information given is complied with. The Firm shall not be answerable for damage caused by failure to comply with the instructions featured herein.**

**While we will not alter the product's essential features, the Firm reserves the right, at any time, to make those changes deemed opportune to improve the product from a technical, design or commercial point of view, and will not be required to update this publication accordingly.**

# INSTALLATION MANUAL

## 1) GENERAL INFORMATION

The **PERSEO CBD 230.P SD** control board comes with standard factory settings. Any change must be made using the programmer with built-in display. Its main features are:

Control of up to 4 bollards: STOPPY MBB -500 C. - STOPPY MBB 219-700 C.

Note: Bollards of the same type must be used.

- Separate inputs for safety devices

- Built-in radio receiver rolling code with transmitter cloning.

The board has a terminal strip of the removable kind to make maintenance or replacement easier. It comes with a series of prewired jumpers to make the installer's job on site easier. If the terminals are being used, remove the relevant jumpers.

Code by means of	Rolling-code algorithm
N° of combinations	4 billion
<b>RADIO CHANNEL FUNCTIONALITY</b>	
PR1	Select the command from parameter R1
PR 2	Closes the relay contact on the terminal block J4 "2nd CH RX"

(\* other voltages to order)

### Usable transmitter versions:

**All ROLLING CODE transmitters compatible with ((€R-Ready))**

## 3) TUBE ARRANGEMENT Fig. A

## 4) CONTROL PANEL DIMENSIONS Fig.B

## 5) TERMINAL BOARD WIRING Fig. C

**WARNINGS** - When performing wiring and installation, refer to the standards in force and, whatever the case, apply good practice principles.

Wires carrying different voltages must be kept physically separate from each other, or they must be suitably insulated with at least 1mm of additional insulation. Wires must be secured with additional fastening near the terminals, using devices such as cable clamps.

All connecting cables must be kept far enough away from the dissipater.



**WARNING!** For connection to the mains power supply, use a multicore cable with a cross-sectional area of at least 3x1.5mm<sup>2</sup> of the kind provided for by the regulations in force.

To connect the motors, use a cable with a cross-sectional area of at least 1.5mm<sup>2</sup> of the kind provided for by the regulations in force. By way of example, if the cable is run outside (unprotected), it must be at least type H07RN-F, while if it is run inside (in a raceway), it must be at least type H05 VV-F.

2) TECHNICAL SPECIFICATIONS	
Power supply*	220-230V 50-60Hz (*)
Motor output	220-230V~; 3A max
Flashing light/traffic light	220-230V~; 40W
Accessory output:	24V~; 1A max
LED Output	24V~ 0,1A max
Buzzer Output	24V~ 0,1A max
Aux Contact	Max 24V 0,5A
2nd Ch rx Contact	Max 24V 0,5A
Low voltage/mains insulation	>2Mohm 500Vdc
Operating temperature range	-20° C+ 60° C
Thermal overload	protection built into motor
Dielectric rigidity	mains/LV 2500Vac for 1 second
Dimensions	See Fig.B
Fuses	See Fig.C
3) RECEIVER TECHNICAL SPECIFICATIONS	
Max. n° of radio transmitters that can be memorized	2048
Frequency	433.92 MHz





## POWER TERMINAL BLOCK J2

Terminal	Description
	Single-phase power supply 220-230V 50/60Hz, with earth cable L Live N Neutral E Earth
	Motor connection MOTA Motor opening COM Motor Common MOTB Motor closing
	Motor capacitor
	Not used
	SL Flashing Light - max. 40W SL-COM/ GR-RD-COM 230V GR Green Light - max. 40W RD Red Light - max. 40W

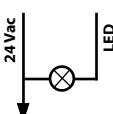

# INSTALLATION MANUAL

D811944\_03

## POWER TERMINAL BLOCK J5

Terminal	Description
 <p>24 Vac</p>	<b>OUT24</b> Output 24V~, 1A MAX
	<b>LED (Cover lights)</b> Self-powered output. 24V~, 100mA max
	<b>BZ (Cover buzzer)</b> Self-powered output. 24V, 100mA max
	<b>AUX</b> Free contact relay output; 500mA max, 24V / Vdc
	<b>2nd CH RX</b> Built-in radio receiver 2nd channel N.O. output, max. 500mA, 24 Vac/Vdc

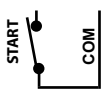
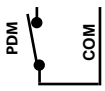
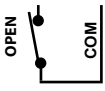
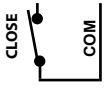
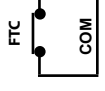
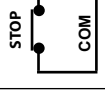
## INPUTS TERMINAL BLOCK J9

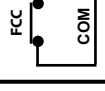
Terminal	Description
	<b>START</b> N.O. input that operates the bollard's opening and closing. The command is ignored while opening.
	<b>PDM</b> Programmable input. Use parameters <i>FP</i> , <i>Pd</i> and <i>Rd</i> for the setting procedure.
	<b>OPEN</b> N.O. input - opening only Connect clocks, daily timers or weekly timers here if wanted. By keeping this input controlled, the automation performs the opening manoeuvre and will close automatically only when the input is freed.
	<b>CLOSE</b> N.O. input for closing. It allows the automation to be closed only if the safety devices have not triggered.
	<b>FTC</b> NC safety input (photocell). Enter the programme wanted by programming the <i>Ft</i> parameter. It triggers only in the closing phase; it never triggers in opening.
	<b>STOP</b> N.C. safety input. When it is activated, the automation is immediately stopped. During the pause time, a stop control eliminates the automatic closing, leaving the bollard open waiting for a command.
	<b>FCA</b> Opening limit switch N.O. input. . When activated the opening travel finishes.
	Not used

## INPUTS TERMINAL BLOCK J10.

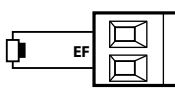
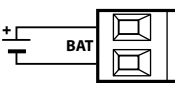
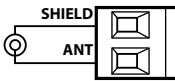
Terminal	Description
	<b>EF Electric brake output</b> Connection for two white power supply cables for the motor's parking electric brake. Activation is possible only when the bollard is completely lifted.
	<b>BAT Input for anti blackout electric brake feeder.</b> Permits the continuous power supply of the electric brake even without electrical energy, preventing the bollard from lowering spontaneously in case of a blackout. Do not connect the batteries directly to this input but request the original accessory STOPPY BAT.
	<b>ANTENNA</b> Antenna connection for the integrated receiver.



## 6) SELECT BOLLARD FIG.D

Set the type of motor connected to the board

## 7) CONNECTIONS FOR SIMULTANEOUS OPERATION FIG.E

The **PERSEO CBD 230.P SD** control unit can be used to operate up to four bollards connected in parallel, thus achieving simultaneous operation with a single control panel.

Use a junction box with a suitable protection rating to wire the bollards together so as to avoid bulky connections near the control panel.

**MOTOR CABLES:** Connect in parallel, observing the motors' polarity by joining together the black cables, brown cables and blue cables.

**CAPACITOR CABLES:** Connect in parallel in the terminals provided

**ELECTRONIC BRAKE CABLES:** Connect in parallel in the terminals provided

**LIGHT CABLES:** Connect in parallel in the terminals provided

**OPENING LIMIT SWITCH CABLES:** Connect in series in the terminals provided

**BUZZER CABLES:** Connect in parallel in the terminals provided

## 8) CALLING UP MENUS : FIG.1

8.1) LEVEL 1 PROGRAMMING MENU (TABLE "A")

8.2) LEVEL 2 PROGRAMMING MENU (TABLE "B")

8.3) LEVEL 3 PROGRAMMING MENU (TABLE "C")

## 9) TROUBLESHOOTING

If you encounter a malfunction of any kind, make sure that you have selected the correct bollard (FIG.D).

- Lights on top cap double flashing. Indicates scheduled maintenance is due.

Check  $5r$ ,  $nL$  and  $nL$  parameters

- Lights on top cap triple flashing and status 14 or 15 on display at end of operation. Check the opening limit switch

## 10) WIRELESS PROGRAMMING

### 10.1) MANUAL PROGRAMMING

In the case of standard installations where no advanced functions are required, it is possible to proceed to manual storage of the transmitters, making referen-

ce to programming table A and to the example for basic programming.

1) If you wish the transmitter to activate output 1, press pushbutton PR1, otherwise if you wish the transmitter to activate output 2, press pushbutton PR2.

2) When LED DL1 starts blinking, press hidden key on the transmitter, LED DL1 will remain continuously lit.

3) Press the key of the transmitter to be memorized, LED DL1 will flash quickly to indicate that it has been memorized successfully. Flashing as normal will then be resumed.

4) To memorize another transmitter, repeat steps 2) and 3).

5) To exit memorizing mode, wait for the LED to go off completely or press the key of a remote control that has just been memorized.

### IMPORTANT NOTE: ATTACH THE ADHESIVE KEY LABEL TO THE FIRST MEMORIZED TRANSMITTER (MASTER).

In the case of manual programming, the first transmitter assigns the key code to the receiver; this code is necessary in order to carry out subsequent cloning of the radio transmitters.

### 10.2) SELF-LEARNING MODE PROGRAMMING

This mode is used to copy the keys of a transmitter already stored in the receiver memory, without accessing the receiver.

The first transmitter is to be memorised in manual mode (see paragraph 8.4).

a) Press hidden key on the transmitter already memorised.

b) Press key T on the transmitter already memorised, which is also to be attributed to the new transmitter.

c) Within 10 s., press hidden key on the new transmitter to be memorised.

d) Press key T to be attributed to the new transmitter.

e) To memorise another transmitter, repeat the procedure from step (c) within a maximum time of 10 seconds, otherwise the receiver exits the programming mode.

f) To copy another key, repeat from step (a), having waited for the receiver to exit the programming mode (or after disconnecting the receiver from the power supply).

ENGLISH

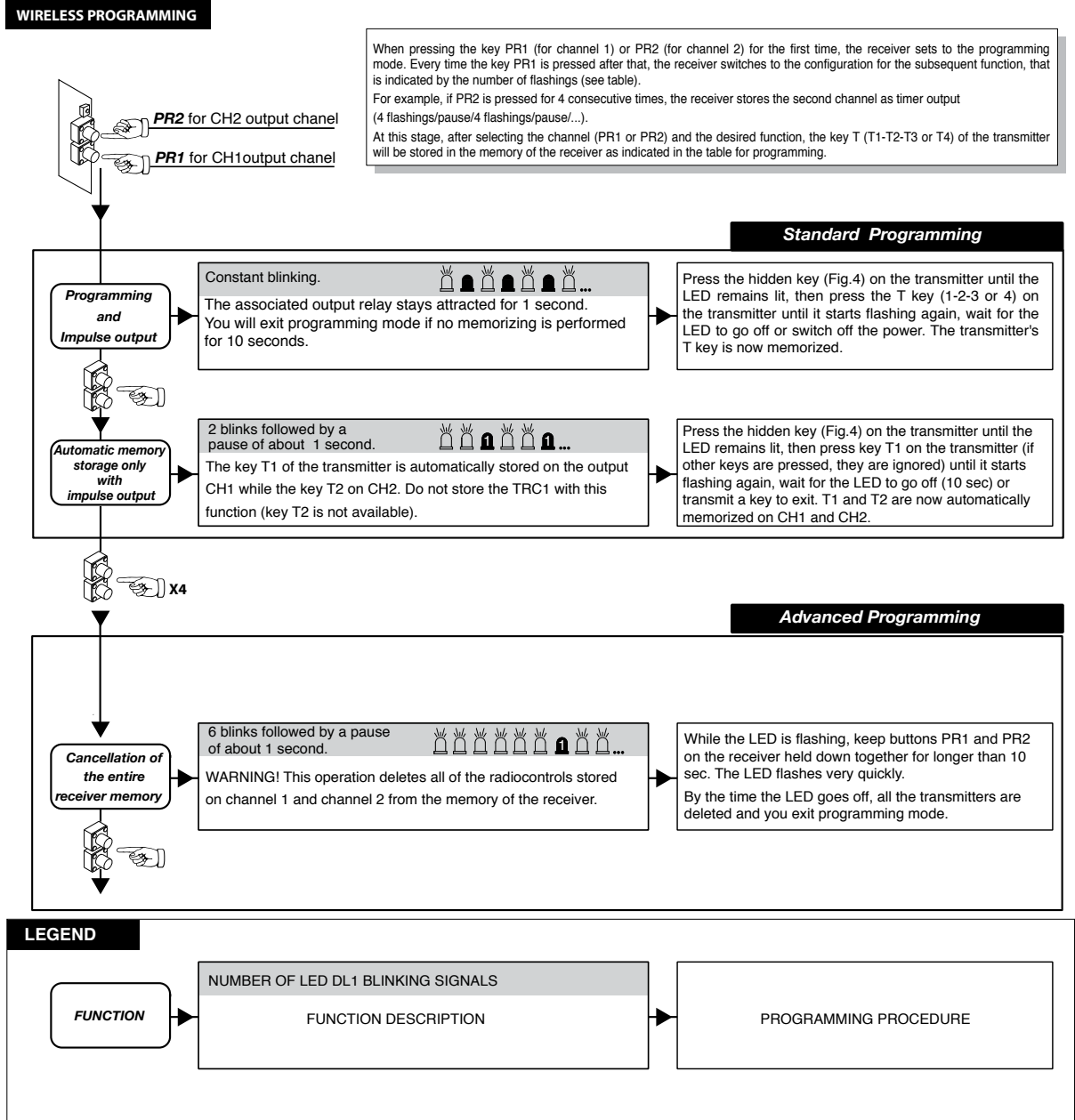

**TABLE "A" - LEVEL 1° PROGRAMMING**

Parameter	Definition	Default	Cross Out Setting Used	Optional Extras	Description
<b>L<sub>o</sub></b>	Selects the functioning logic.	<b>01</b>	00	Hold-to-run	The automation works when the commands are held down. The start command opens once and closes once.
			01	Semi automatic	The automation works with jog commands, without automatic reclosing. Hence, when fully open, to control closing you need to act on the start or close command respectively.
			02	Automatic	The automation works in jogs. When the opening manoeuvre is completed in the standard cycle, automatic reclosing is activated after the pause time set (parameter tP).
<b>cL</b>	Close input configuration	<b>00</b>	00	Standard close input	The command causes the device to close
			01	Close-when-released input	Close-when-released input This mode has been developed so the bollard closes automatically only when the vehicle has completely passed by the photocell or magnetic detector (the most suitable accessories for this purpose). Connect the NO contact of the detector or photocell to the Close contact terminals. If the vehicle is on the detector or in front of the photocell it does not cause immediate closing but rather you have to wait for the signal to be released.
			02	The close command acts as a release closing and safety function.	The close command acts as a release closing and safety function. When closing, the close command engaging stops the automation. When disengaged the bollard resumes closing.
<b>Ft</b>	Photocells	<b>02</b>	00	During closure, it reopens and waits for the photoelectric cell free commands.	
			01	When closing it reopens; reclosing after 1" when the photocell is disengaged	
			02	When closing it reopens; reclosing after 5" when the photocell is disengaged	
<b>ob</b>	Not available	<b>03</b>	00	Not available	
			01		
			02		
			03		
<b>PF</b>	Warning flash	<b>00</b>	0-30		Before each start, the flashing light is activated, for the set time, along with the AUX output, if set (R <sub>U</sub> parameter). A 0 pre-flashing is disabled.
<b>L<sub>d</sub></b>	Bollard lights	<b>00</b>	00	Cover lights flashing during movement, cover lights fixed when the bollard is opened and closed	
			01	Cover lights flashing during movement and with bollard closed, cover lights fixed when the bollard is open	
			02	Cover lights always flashing	
			03	Cover lights flashing during movement and with bollard open, cover lights fixed when the bollard is closed	
<b>bU</b>	Buzzer	<b>01</b>	00	Buzzer off	
			01	Buzzer on during movement	
<b>dF</b>	Resetting default parameters.	<b>00</b>	00	No resetting	To reset the default parameters, set parameter dF on 1 and exit the menu'.
			01	Resetting the default parameters.	
			02	Not available	
			03		
			04		
			05		
<b>tP</b>	Pause time (expressed in seconds)	<b>10</b>	1-99		Waiting time before automatic closing in Automatic mode (L <sub>o</sub> parameter).

TABLE "B" - LEVEL 2° PROGRAMMING

Parameter	Definition	Default	Cross Out Setting Used	Optional Extras	Description
5r	Request for maintenance	00	00	disabled	the request for maintenance is not active.
			01	active on the configured outputs	at the end of the countdown, by means of counters nt and nL, one of the programmed outputs is activated (see parameter Ru)
			02	active on the configured outputs and the bollard lights flash twice	at the end of the countdown, by means of counters nt and nL, one of the programmed outputs is activated (see parameter Ru) and the bollard lights flash twice.
nt	Programming maintenance cycles in thousands	00	00-99		Thanks to the combination of the two parameters the countdown can be set after which a request for maintenance is signalled. Thousands can be set with the nt parameter, millions with the nL parameter. Example: to set 275,000 maintenance manoeuvres set nL on 0.2 and nt on 75. The value displayed in the parameters updates along with the manoeuvres.
nL	Programming maintenance cycles in millions	0.0	00-99		
Ru	AUX	00	00	scheduled maintenance required	If the maintenance request is enabled (5r parameter), the AUX output is activated once the value set for parameter nt and nL is reached.
			01	photocell triggering	The AUX output is activated if the photocell input is open, photocell triggered.
			02	§ non disponibile	
			03	PDM contact actuated	The AUX output is activated if the PDM input is closed.
			04	bollard closed	The AUX output is activated when the bollard is closed.
			05	bollard open	The AUX output is activated when the bollard is open.
			06	stop contact actuated	The AUX output is activated if the Stop input is open.
			07	warning flash	The AUX output is activated as described in the PF pre-flashing parameter.
			08	start contact	The AUX output is activated if the Start input is closed.
			09	open contact	The AUX output is activated if the Open input is closed.
			10	blackout	The AUX output is activated when the device is switched on
	11	assistance required	If configured, the contact indicates that the electronic control unit has detected an error in the automated device and, more specifically, has detected that the limit switches are broken. Whatever the case, the lights on the top cap triple flash to report the error.		
TE	TERMON	00	00-30		Sets the temperature difference between the bollard's motor and the ambient temperature in centigrade degrees. If the parameter is not zero, the control unit will heat the motor in order to obtain the set temperature difference. Example: TE=15. The control unit will ensure that the motor maintains a temperature that is 15° above the ambient temperature. By setting the parameter FP=3, it is possible to enable or disable the Termon system, operating directly on the PDM input.
cr	Slow-down speed	20	10-45		Sets the deceleration speed at the end of the closing manoeuvre. The value of the deceleration speed at the end of opening is preset by the company.

TABLE "C" - LEVEL 3° PROGRAMMING

Parameter	Definition	Default	Cross Out Setting Used	Optional Extras	Description
<i>Pd</i>	PDM dynamic input polarity	00	00	Input configured as NO	
			01	Input configured as NC	
<i>PR</i>	Output AUX polarity	00	00	Output configured as NO	The outputs can be configured as NO or NC, but in the event of a power outage, the contacts will open anyway
			01	Output configured as NC	
<i>cP</i>	Commands during pause	01	00	OFF	Depending on how the parameter is set, the automated device accepts or rejects commands during pause time..
			01	ON	
<i>FP</i>	Special PDM functions	00	00	None	Not configured.
			01	Opening consent	PDM is used to enable opening. Until it is pressed, no opening command is accepted through the OPEN input. If PDM is held down, no closing command is accepted through the CLOSE input, meaning the bollard stays open.
			02	Opening consent and pause time reset	The PDM functions as described in point 1, but in case of automatic logic, the pause time is reloaded.
			03	TERMON enabling	The PDM function enables the TERMON system. Based on the setting of the PD parameter, the closing or opening of the contact activates or deactivates the TERMON system. This makes it possible to interface a schedule with a potential free contact to optimise the heating system.
<i>ri</i>	Radio channel 1 command selection	01	00	Channel 1 deactivated	
			01	Channel 1 set as START	
			02	Channel 1 set as OPEN	
<i>ht</i>	Select mains frequency	30	20-80		